

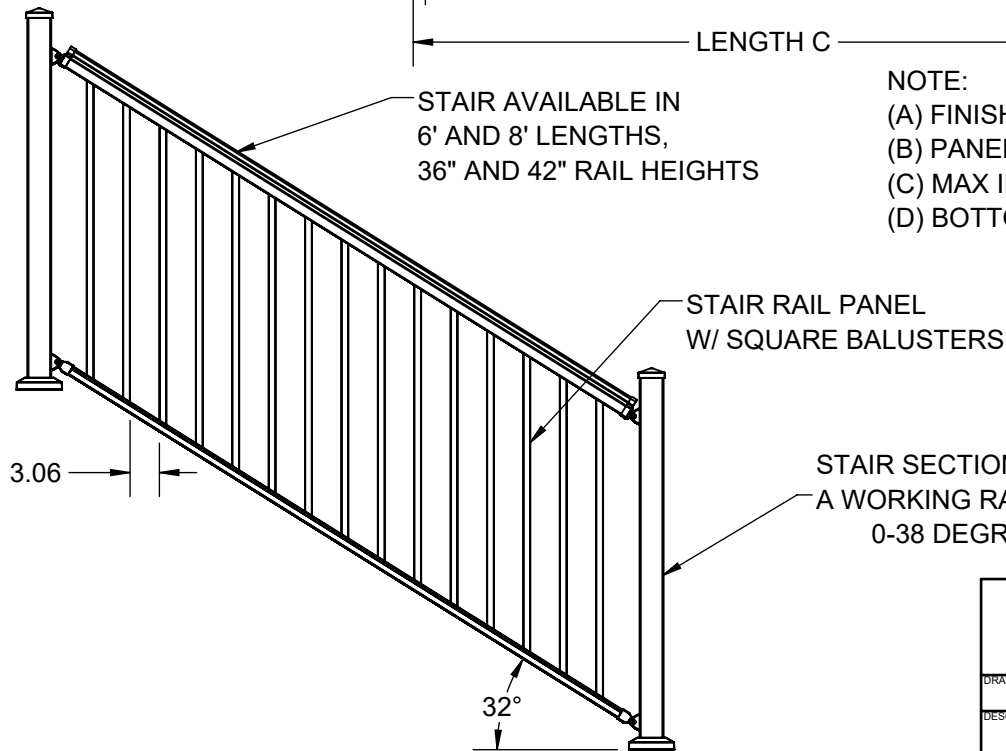

MOISTURESHIELD COMPASS ALUMINUM LEVEL AND STAIR RAIL DETAILS

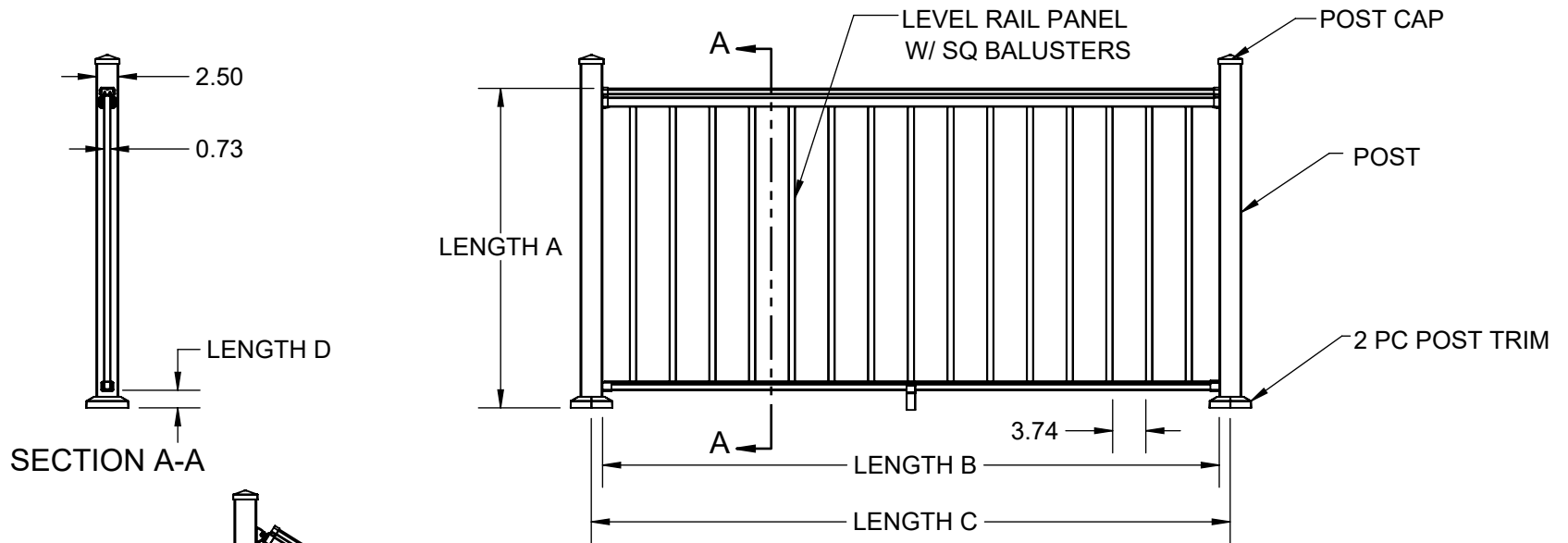

NOTE:
 (A) FINISHED RAIL HEIGHT = 36", 42"
 (B) PANEL LENGTH = 71.5", 95.5"
 (C) MAX IRC AND IBC SPANS = 96"X36", 96"X42"
 (D) BOTTOM SPACE = 2"

STAIR SECTIONS HAVE
A WORKING RANGE OF
0-38 DEGREES.

THE INFORMATION CONTAINED IN THIS DRAWING IS PROTECTED BY COPYRIGHT AND PATENT LAWS OF THE UNITED STATES AND OTHER COUNTRIES. ANY REPRODUCTION IN PART OR AS A WHOLE WITHOUT WRITTEN PERMISSION IS PROHIBITED.

 MoistureShield.	
DRAWN: EP	DATE: 02/27/2023
APPROVED:	
COMPASS LEVEL AND STAIR RAIL	
SHEET 1 OF 12	REVISION PART NUMBER
SCALE 1:20	0
WEIGHT: N/A	N/A

TOP AND BOTTOM RAIL

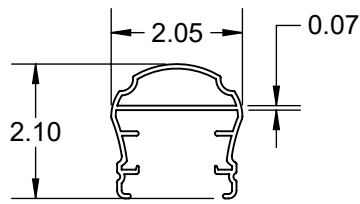

CAMBRIDGE TOP RAIL

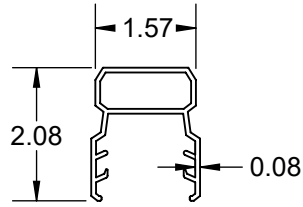

CLASSIC TOP RAIL

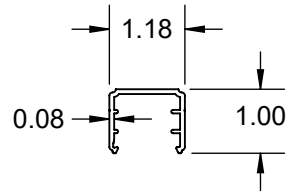

TOP & BOTTOM RAIL

BALUSTERS

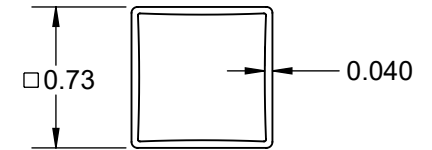

3/4" SQ. BALUSTER

NOTE:

1. BRACKET COVERS ARE INCLUDED WITH TOP RAIL.
2. FANCY TOP RAIL FITS OVER SMALL TOP RAIL.

POSTS

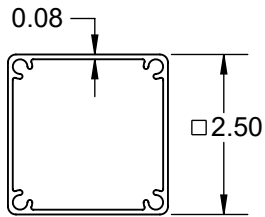

COMPASS POST
RESIDENTIAL/CABLE LINE
RESIDENTIAL

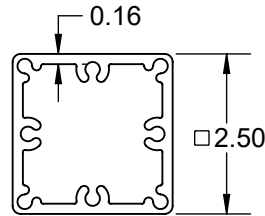

HD COMMERCIAL
& FASCIA POST

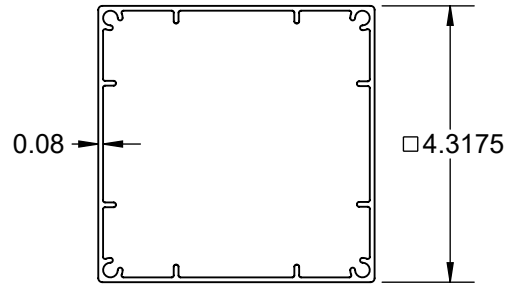

4.25" AR POST

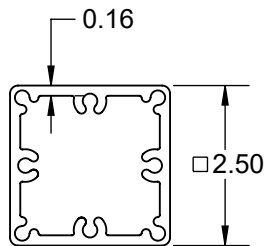

COMPASS HD POST/
CABLE RAILING LINE POST

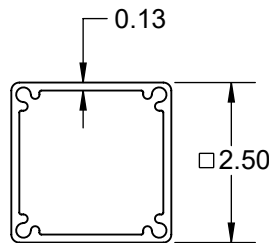

CORNER POST
FOR CABLE RAILING

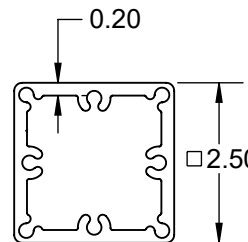

END POST
FOR CABLE RAILING

THE INFORMATION CONTAINED IN THIS DRAWING IS PROTECTED BY COPYRIGHT AND PATENT LAWS OF THE UNITED STATES AND OTHER COUNTRIES. ANY REPRODUCTION IN PART OR AS A WHOLE WITHOUT WRITTEN PERMISSION IS PROHIBITED.



DRAWN: EP DATE: 02/27/2023 APPROVED:

DESCRIPTION: **COMPASS PROFILES**

SHEET 2 OF 12 REVISION PART NUMBER

SCALE 1:3 WEIGHT: N/A  N/A

COMPASS POST AND SURFACE MOUNT DETAILS

NOTE: IMAGES ONLY REFERENCE 2" AND 2.5" POSTS.

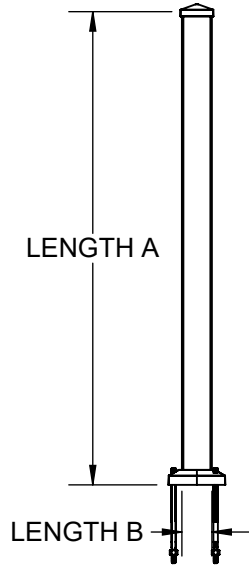

POSTS	LENGTH A	LENGTH B
STD. POST	39"	2.50"
STD. POST	45"	2.50"
STD. POST EXTENSION	65"	2.50"
HD. POST	45"	2.50"
HD. POST	60"	2.50"
FASCIA POST	45"	2.50"
FASCIA POST	52"	2.50"
4.25" AR. POST	39"	4.32"
4.25" AR. POST	45"	4.32"
4.25" AR. POST	108"	4.32"

NOTE:
2.5" POSTS INCLUDE FACTORY MOUNTED BASE PLATE, TWO PICE TRIM, POST CAP, AND LEVELING SHIMS.
4.3125" POST SOLD SEPARATELY AS COMPONENTS.

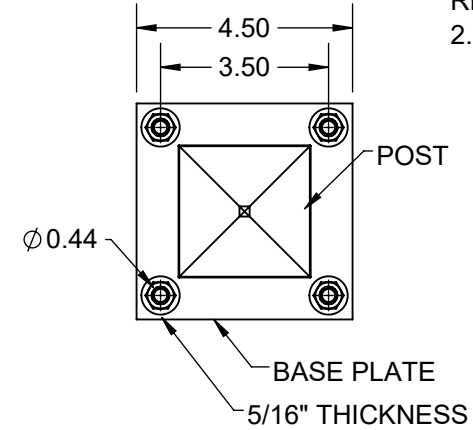

POST BASE CONNECTION INTO CONCRETE WITH WEDGE ANCHORS

POST BASE CONNECTION INTO WOOD WITH THROUGH BOLTS

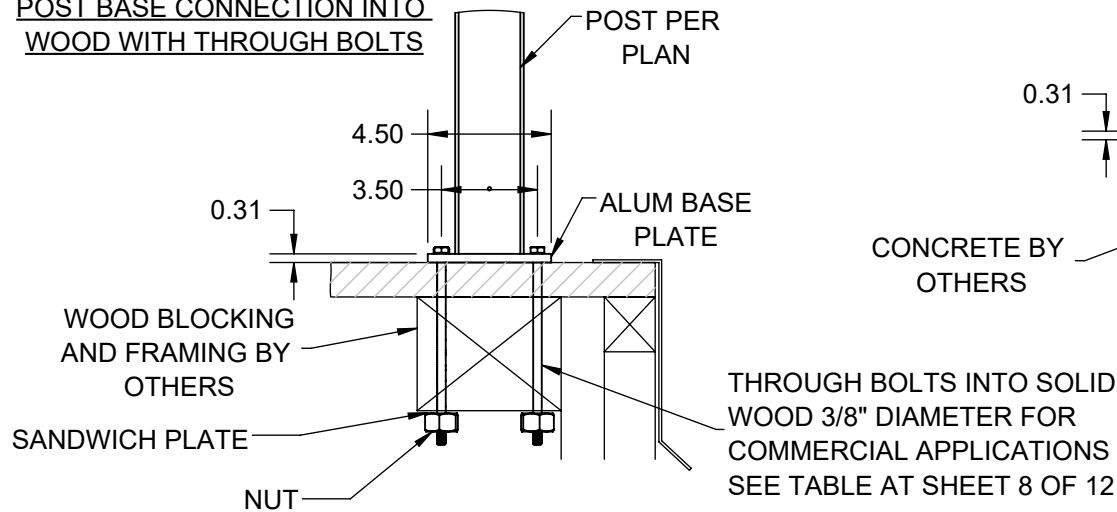

THROUGH BOLTS INTO SOLID WOOD 3/8" DIAMETER FOR COMMERCIAL APPLICATIONS SEE TABLE AT SHEET 8 OF 12

- NOTE:
1. COMMERCIAL APPLICATIONS ARE ALWAYS BOLTED, USE 3/8" DIAMETER A307 THROUGH BOLTS INTO SOLID WOOD BLOCKING.
 2. WOOD BLOCKING BY OTHERS.
 3. BLOCKING MUST BE DESIGNED TO WITHSTAND PROPER LOADING.

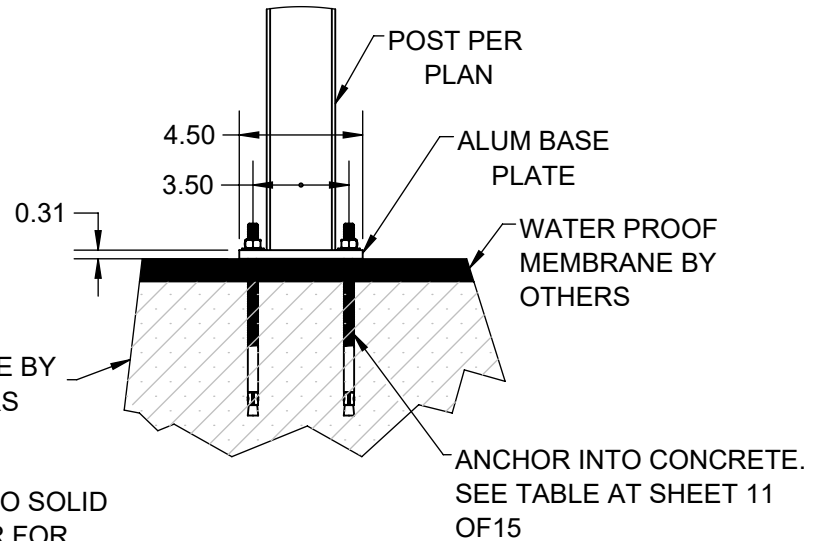

THE INFORMATION CONTAINED IN THIS DRAWING IS PROTECTED BY COPYRIGHT AND PATENT LAWS OF THE UNITED STATES AND OTHER COUNTRIES. ANY REPRODUCTION IN PART OR AS A WHOLE WITHOUT WRITTEN PERMISSION IS PROHIBITED.

DRAWN: EP	DATE: 02/27/2023
APPROVED:	
DESCRIPTION: COMPASS POST AND SURFACE MOUNT	
DETAIL	
SHEET 3 OF 12	REVISION PART NUMBER
SCALE 1:16	
WEIGHT: N/A	N/A

COMPASS POST AND SURFACE MOUNT DETAILS

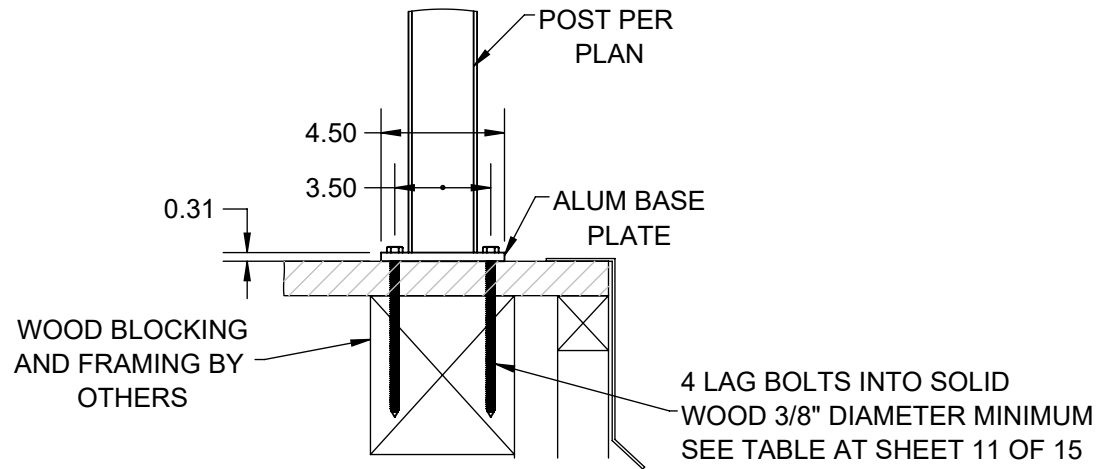

POST BASE CONNECTION INTO
WOOD WITH LAG BOLTS

NOTE:

1. WOOD BLOCKING BY OTHERS.
2. BLOCKING MUST BE DESIGNED TO WITHSTAND PROPER LOADING.

THE INFORMATION CONTAINED IN THIS DRAWING IS PROTECTED BY COPYRIGHT AND PATENT LAWS OF THE UNITED STATES AND OTHER COUNTRIES. ANY REPRODUCTION IN PART OR AS A WHOLE WITHOUT WRITTEN PERMISSION IS PROHIBITED.

 MoistureShield.		
DRAWN: EP	DATE: 02/27/2023	APPROVED:
DESCRIPTION: COMPASS POST AND SURFACE MOUNT		
DETAIL		
SHEET 4 OF 12	REVISION	PART NUMBER
SCALE 1:16	0	N/A
WEIGHT: N/A		

FASCIA MOUNT DETAILS

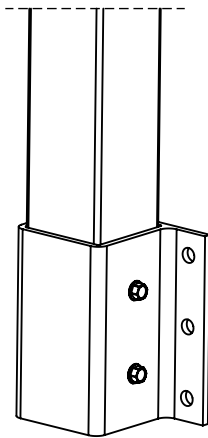
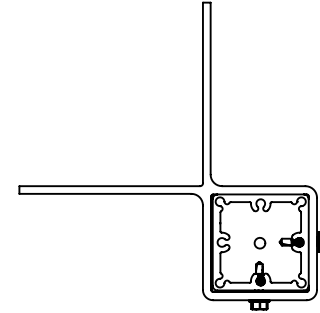
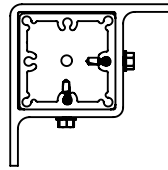
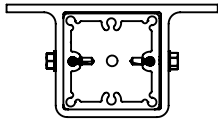

LINE POST / END POST
BRACKET

4X #14 SCREW

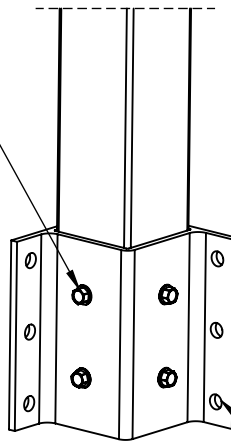

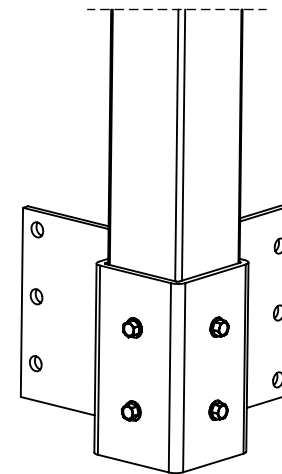

INSIDE CORNER POST
BRACKET

SEE TABLE AT
SHEET 11 OF 15
FOR ANCHOR
SCHEDULE



OUTSIDE CORNER POST
BRACKET

THE INFORMATION CONTAINED IN THIS DRAWING IS PROTECTED BY COPYRIGHT AND PATENT LAWS OF THE UNITED STATES AND OTHER COUNTRIES. ANY REPRODUCTION IN PART OR AS A WHOLE WITHOUT WRITTEN PERMISSION IS PROHIBITED.

		
DRAWN: EP	DATE: 02/27/2023	APPROVED:
DESCRIPTION: FASCIA MOUNT DETAIL		
SHEET 5 OF 12	REVISION	PART NUMBER
SCALE 1:5		N/A
WEIGHT: N/A		

FASCIA MOUNT - JULIET DETAIL

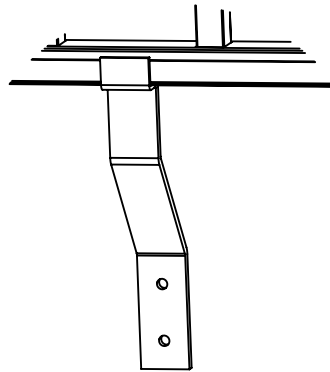
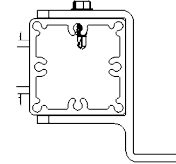
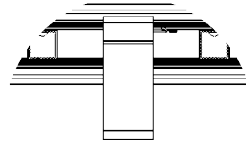

2X #14 SCREWS

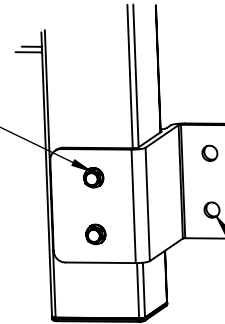

SEE TABLE AT
SHEET 11 OF 15
FOR ANCHOR
SCHEDULE

FASCIA MOUNT JULIET
SUPPORT FOOT

FASCIA MOUNT
JULIET BRACKET

THE INFORMATION CONTAINED IN THIS DRAWING IS PROTECTED BY COPYRIGHT AND PATENT LAWS OF THE UNITED STATES AND OTHER COUNTRIES. ANY REPRODUCTION IN PART OR AS A WHOLE WITHOUT WRITTEN PERMISSION IS PROHIBITED.

 MoistureShield.		
<small>DRAWN:</small> EP	<small>DATE:</small> 02/27/2023	<small>APPROVED:</small>
<small>DESCRIPTION:</small> FASCIA MOUNT - JULIET DETAIL		
SHEET 6 OF 12	<small>REVISION</small>	<small>PART NUMBER</small>
SCALE 1:5	0	N/A
WEIGHT: N/A		

MOUNTING SCHEDULE

FOR RESIDENTIAL APPLICATIONS 36" HIGH					
PANEL WIDTH	LOAD	RECOMMENDED BOLT APPLICATION	FOR LAG BOLT APPLICATION 3/8" DIA. SCREW. MINIMUM EMBEDDED SCREW THREAD LENGTH REQUIRED	FOR THROUGH BOLT APPLICATION	FOR CONCRETE ANCHOR APPLICATION 3/8" TITAN HD ANCHOR MINIMUM REQUIRED LENGTH (MINIMUM DISTANCE OF 4" FORM EDGE REQUIRED)
8FT	200LBS	LAG BOLT -OR- THROUGH BOLT -OR- CONCRETE ANCHOR	3.5IN	3/8" HEX BOLT 3/8" FLAT WASHER 3/8" LOCK WASHER 3/8" NUT	4IN
6FT			3IN		3IN
4FT			2.5IN		3IN

FOR COMMERCIAL APPLICATIONS 42" HIGH					
PANEL WIDTH	LOAD	RECOMMENDED BOLT APPLICATION	FOR LAG BOLT APPLICATION 3/8" DIA. SCREW. MINIMUM EMBEDDED SCREW THREAD LENGTH REQUIRED	FOR THROUGH BOLT APPLICATION	FOR CONCRETE ANCHOR APPLICATION 3/8" TITAN HD ANCHOR MINIMUM REQUIRED LENGTH (MINIMUM DISTANCE OF 4" FORM EDGE REQUIRED)
8FT	400LBS	THROUGH BOLT -OR- CONCRETE ANCHOR	3.5IN	3/8" HEX BOLT 3/8" FLAT WASHER 3/8" LOCK WASHER 3/8" NUT	4IN
6FT	300LBS	LAG BOLT -OR- THROUGH BOLT -OR- CONCRETE ANCHOR	3IN		3IN
4FT	200LBS	LAG BOLT -OR- THROUGH BOLT -OR- CONCRETE ANCHOR	2.5IN		3IN



DRAWN:	EP	DATE:	02/27/2023	APPROVED:
DESCRIPTION:				
MOUNTING SCHEDULE				
SHEET 7 OF 12		REVISION	PART NUMBER	
SCALE 1:16		0	N/A	
WEIGHT: N/A				

THE INFORMATION CONTAINED IN THIS DRAWING IS PROTECTED BY COPYRIGHT AND PATENT LAWS OF THE UNITED STATES AND OTHER COUNTRIES. ANY REPRODUCTION IN PART OR AS A WHOLE WITHOUT WRITTEN PERMISSION IS PROHIBITED.

BRACKETS & ACCESSORIES

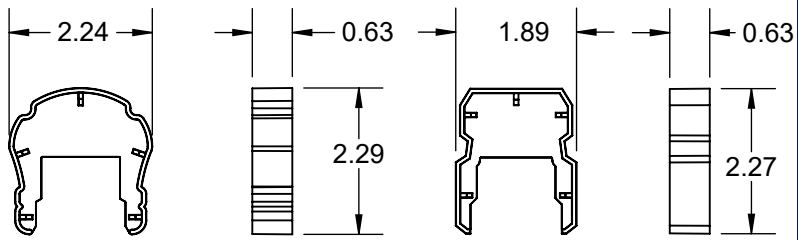

CAMBRIDGE
TOP COVER

CLASSIC
TOP COVER



BOTTOM COVER

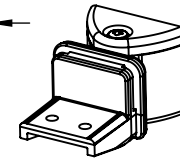
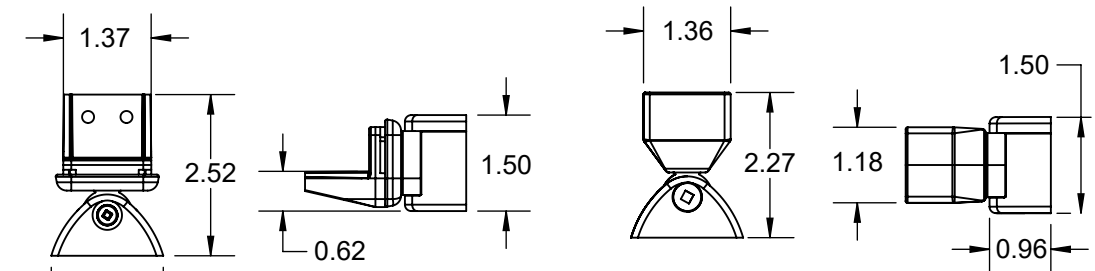

TOP BRACKET

*TOP COVER IS THE SAME AS LEVEL BRACKET

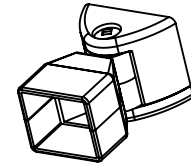

BOTTOM BRACKET

LEVEL ANGLE BRACKETS

STAIR BRACKETS

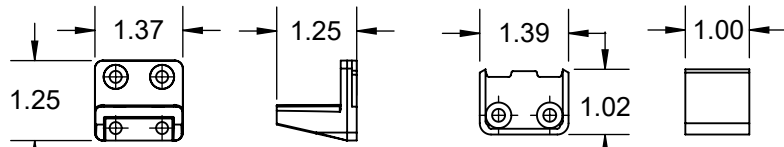

TOP BRACKET

BOTTOM BRACKET

LEVEL BRACKETS

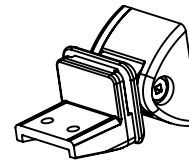
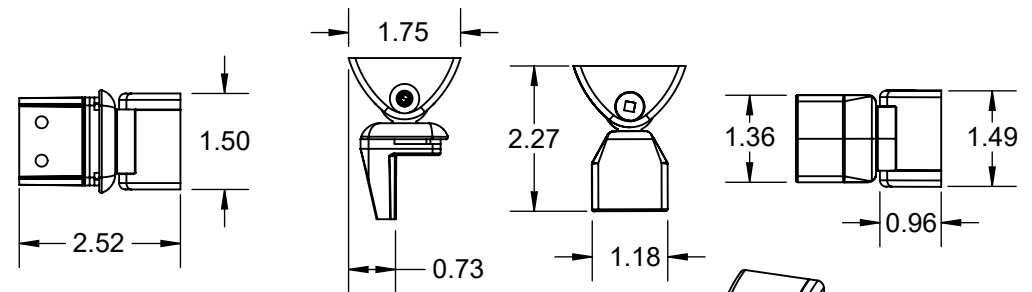

TOP BRACKET

*TOP COVER IS THE SAME AS LEVEL BRACKET

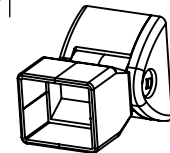

BOTTOM BRACKET



DRAWN: EP	DATE: 02/27/2023	APPROVED:
DESCRIPTION: COMPASS ACCESSORIES		
SHEET 8 OF 12	REVISION	PART NUMBER
SCALE 1:3	0	N/A
WEIGHT: N/A		

ACCESSORIES

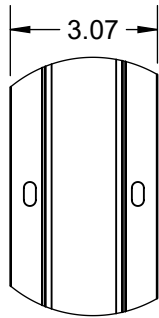
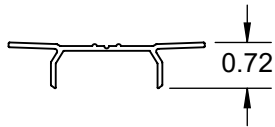

DECK TOP ADAPTER
6' AND 8' LENGTHS
HOLES EVERY 1'



(2) J-HOOKS
INCLUDED

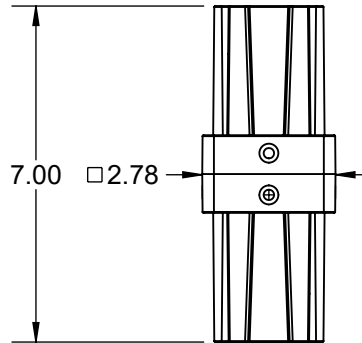
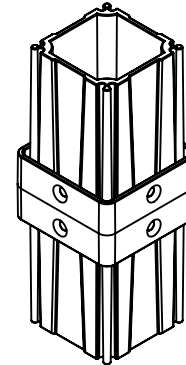
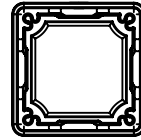

POST EXTENSION

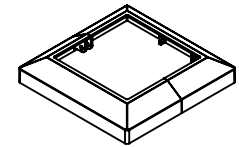
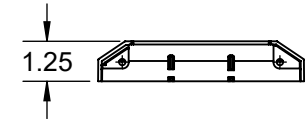
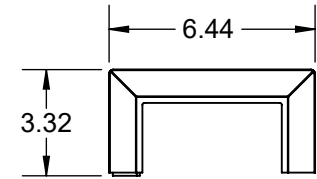

4.25" TRIM RING

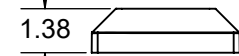
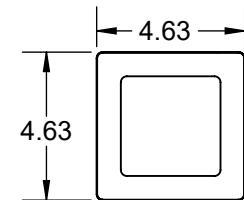

4.25" FLAT POST CAP

4.25" MOUNTING KIT

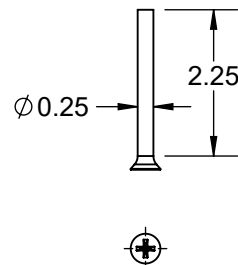
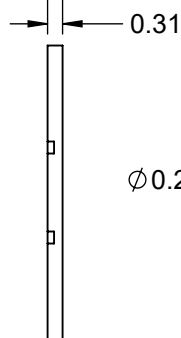
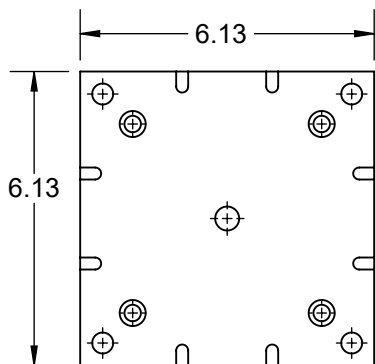

108" POST SLEEVE CAN BE USED AS A STRUCTURAL POST
(REQUIRES 2 MOUNTING KITS)

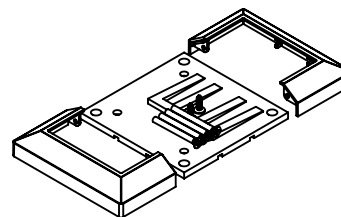

MOUNTING KIT COMES WITH TRIM RING

DRAWN: EP	DATE: 02/27/2023	APPROVED:
DESCRIPTION: COMPASS ACCESSORIES		
SHEET 9 OF 12	REVISION	PART NUMBER
SCALE 1:4		N/A
WEIGHT: N/A		

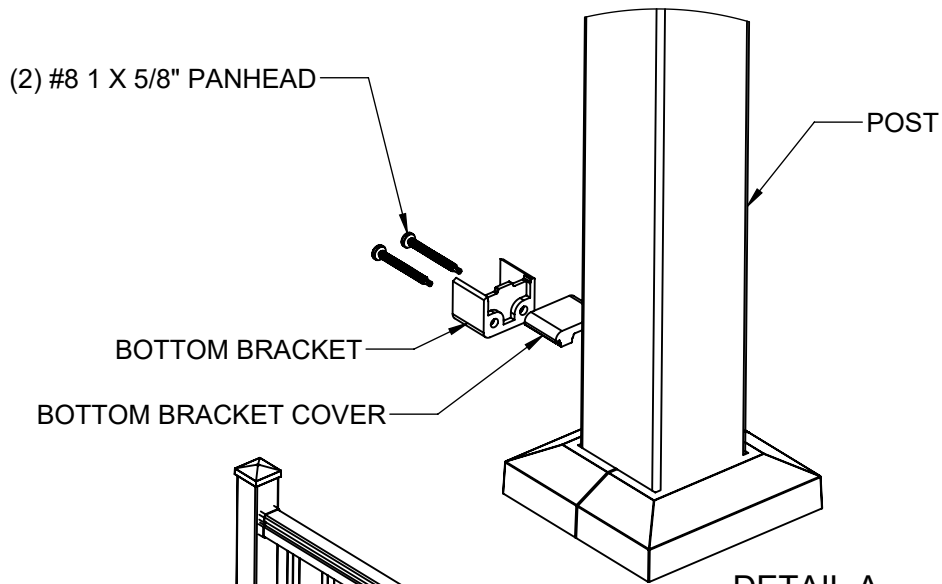

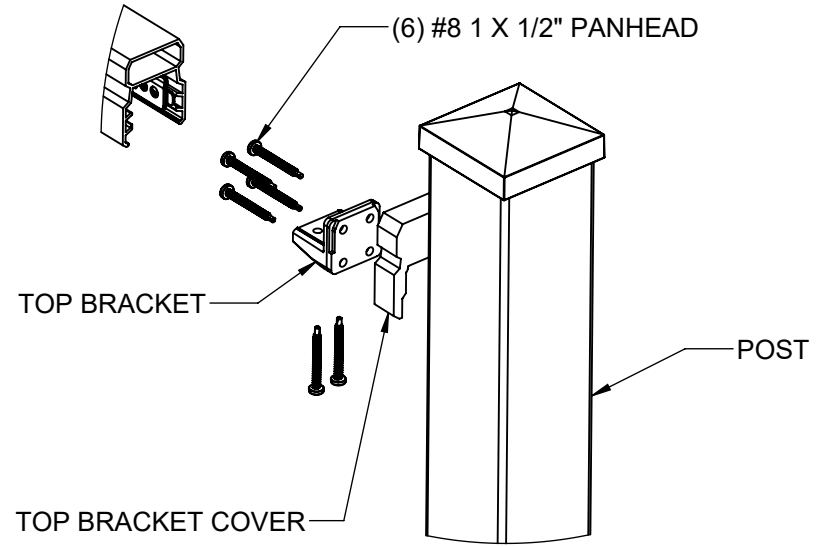

DETAIL A
SCALE 1 : 4

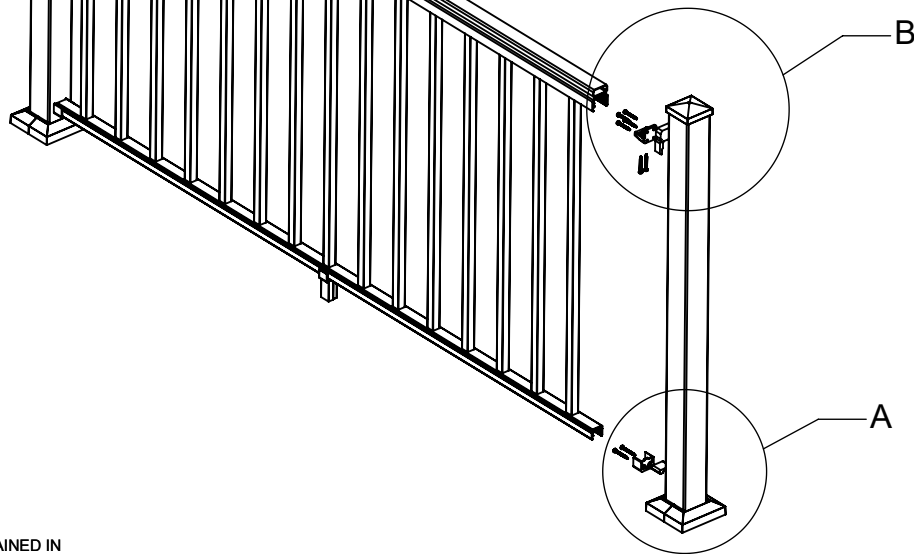

DETAIL B
SCALE 1 : 4



THE INFORMATION CONTAINED IN THIS DRAWING IS PROTECTED BY COPYRIGHT AND PATENT LAWS OF THE UNITED STATES AND OTHER COUNTRIES. ANY REPRODUCTION IN PART OR AS A WHOLE WITHOUT WRITTEN PERMISSION IS PROHIBITED.

 MoistureShield.		
DRAWN: EP	DATE: 02/27/2023	APPROVED:
DESCRIPTION: COMPASS FASTENER DETAIL		
SHEET 10 OF 12	REVISION	PART NUMBER
SCALE 1:16		N/A
WEIGHT: N/A		

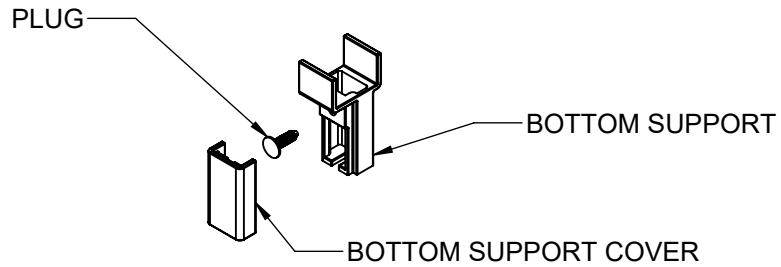

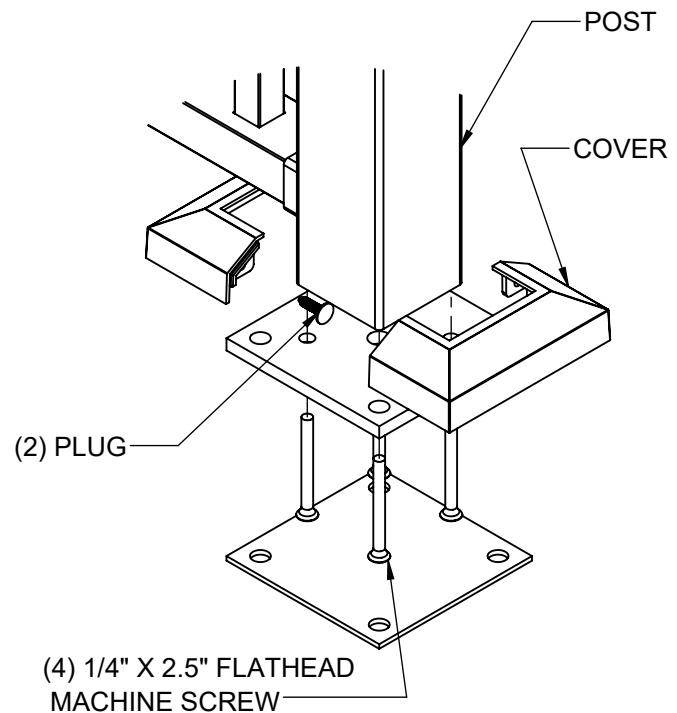
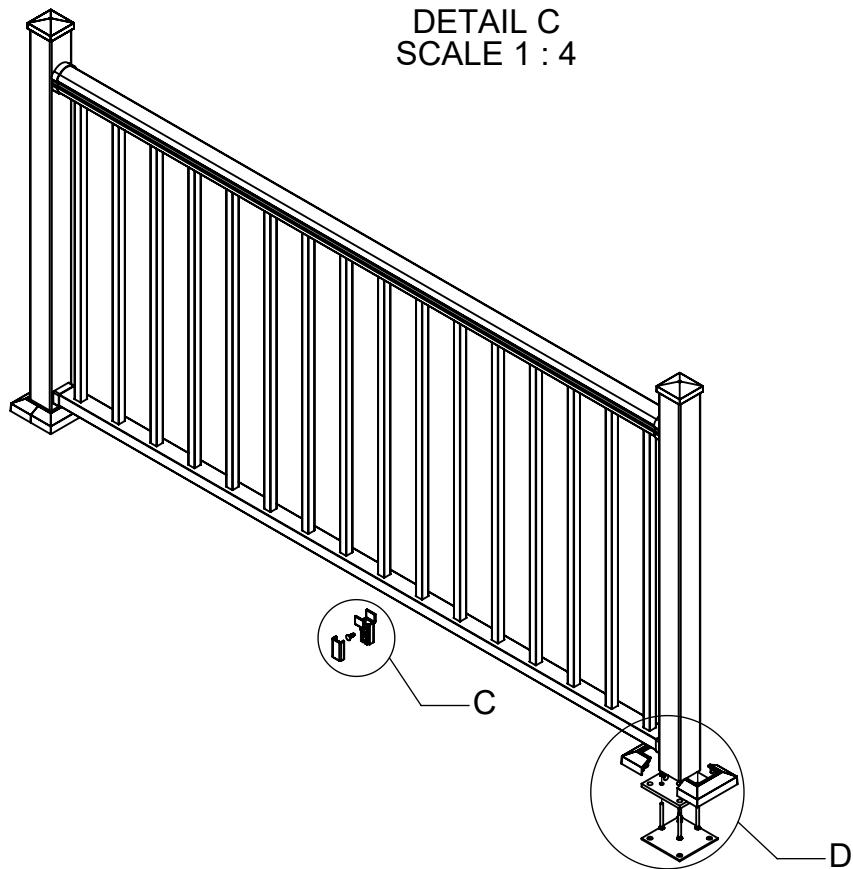

DETAIL C
SCALE 1 : 4



DETAIL D
SCALE 1 : 4

THE INFORMATION CONTAINED IN THIS DRAWING IS PROTECTED BY COPYRIGHT AND PATENT LAWS OF THE UNITED STATES AND OTHER COUNTRIES. ANY REPRODUCTION IN PART OR AS A WHOLE WITHOUT WRITTEN PERMISSION IS PROHIBITED.

		
DRAWN: EP	DATE: 02/27/2023	APPROVED:
DESCRIPTION: COMPASS FASTENER DETAIL		
SHEET 11 OF 12	REVISION	PART NUMBER
SCALE 1:16		N/A
WEIGHT: N/A		

CABLE RAILING PANEL-DETAILS

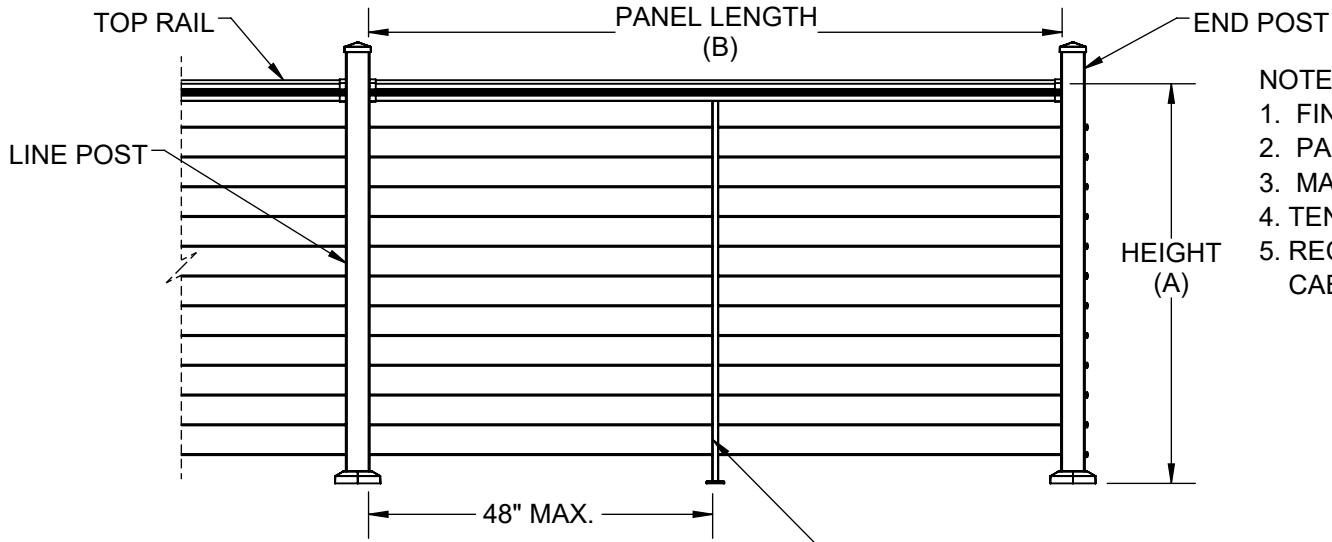

NOTE:

1. FINISHED RAIL HEIGHT (A) = 36", 42"
2. PANEL LENGTH (B) = 71.5", 95.5"
3. MAX PANEL SIZE = 96X36" IRC, 96X42" IBC
4. TENSION CABLE TO PREVENT PASSING 4" SPHERE.
5. RECOMMENDED PULLING FORCE FROM CABLE MANUFACTURER 225 LBS

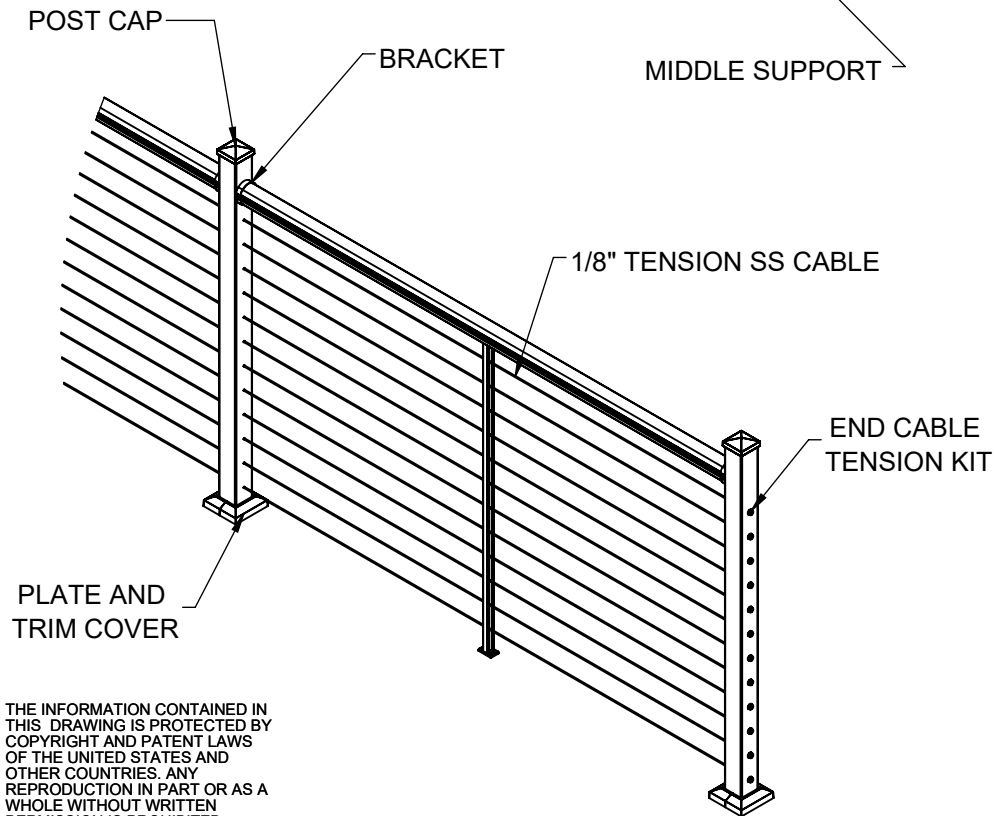

STAIR KITS AVAILABLE IN 6' AND 8' LENGTHS, 36" AND 42" RAIL HEIGHTS

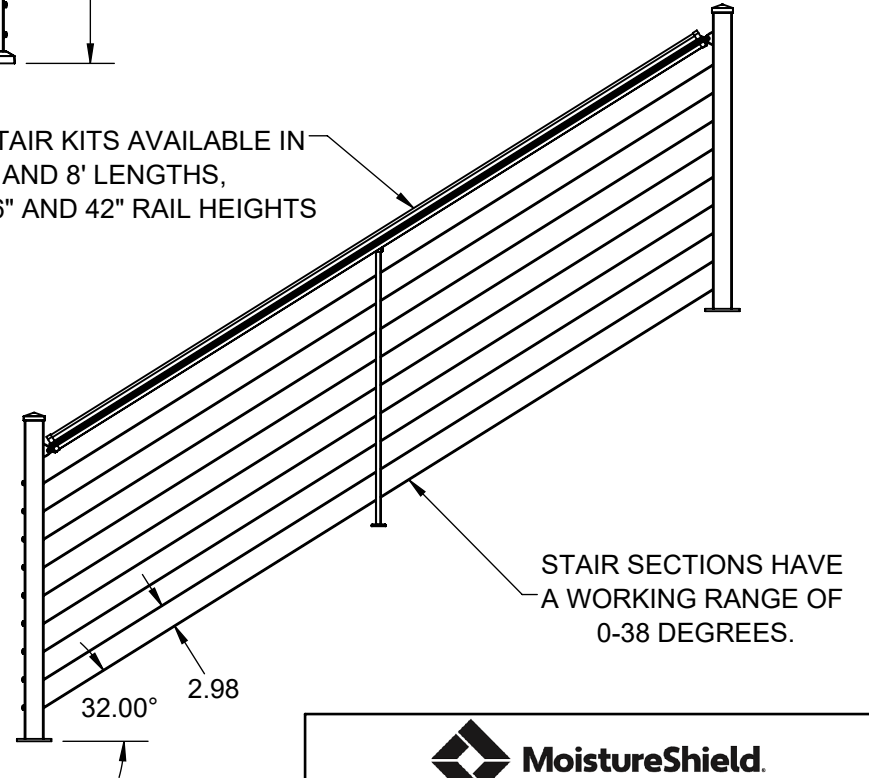

THE INFORMATION CONTAINED IN THIS DRAWING IS PROTECTED BY COPYRIGHT AND PATENT LAWS OF THE UNITED STATES AND OTHER COUNTRIES. ANY REPRODUCTION IN PART OR AS A WHOLE WITHOUT WRITTEN PERMISSION IS PROHIBITED.

		
DRAWN: EP	DATE: 02/27/2023	APPROVED:
DESCRIPTION: CABLE RAILING - DETAILS		
SHEET 12 OF 12	REVISION	PART NUMBER
SCALE 1:25	0	N/A
WEIGHT: N/A		