



PFS TECO Research Report 0111

Date of Acceptance: June 19, 2017
Visit www.pfsteco.com for current status

Expiration Date: June 19, 2018

Revision Date: _____
Page: 1 of 7

TYPE OF ACCEPTANCE: Product Material - Wood and Plastics
CSI Specification Division 060000 (Structural Plastic) and Section 066300
(Plastic Railing)

MANUFACTURER IDENTIFICATION: Advanced Environmental Recycling Technologies, Inc. (AERT)
914 North Jefferson Street
Springdale, AR 72764
1-479-756-7400
www.aert.com

RESEARCH REPORT SUBJECT: AERT, Inc., Guardrails for Exterior Applications
Installation on construction complying with the International Residential Code
(IRC) or complying with the International Building Code (IBC) and IBC
Exceptions in Section 1015.3 of the IBC.

DESCRIPTION OF BUILDING COMPONENTS:

A. Guardrails

AERT, Inc., guardrail is a wood thermoplastic composite lumber (WTCL) product consisting of plastic, wood flour filler plus additives and color. The product specifications are listed in the approved quality control manual. The AERT, Inc., guardrail components are manufactured by a continuous (mono) extrusion process in several colors.

1. The **ChoiceDek™, MoistureShield® and Lifecycle® Basics Guardrail Systems** consist of top rail, bottom rail, balusters and posts. The guardrails come in three configurations – Design 1, Design 2 and Design 3. See Tables 1 and 2 in this report for drawings and dimensions.
 - (a) The top rails have two configurations, are solid, have rounded edges and have the option of a top rail cap. See Table 2 in this report for drawings and dimensions of the top rails.
 - (b) The bottom rail has one configuration, is solid, and has rounded edges. See Table 2 in this report for drawings and dimensions.
 - (c) The baluster is solid, rectangular in shape and has rounded edges. See Table 2 in this report for drawing and dimensions.
 - (d) The guardrail systems come with WTCL posts and optional post sleeves. The WTCL post is square in shape, has round edges and has a square hollow core that is designed for wood post or an optional reinforcing pipe. The optional reinforcing pipe is produced from an ASTM A53, Grade A material. The guardrail systems have an optional post sleeve that is square in shape, is hollow in the center and has round edges. See Tables 2 in this report for drawings and dimensions of post and post sleeve.
 - (e). The fastening for the guardrail top rails, bottom rails and balusters is with deck screws (stainless or corrosion resistant plated) are supplied by the manufacturer. The fastening for the guardrail systems to WTCL posts is with deck screws (stainless or corrosion resistant plated). See Table 2 in this report for drawings and number of fasteners required.
 - (f). See Tables 1 and 2 in this report for the guardrail systems heights and lengths.
 - (g). For additional guardrail installation instructions, see manufacturer's published guardrail systems installation instructions as follows: **MoistureShield®** (Composite) guardrail dated July 2015, **ChoiceDek™** guardrail dated May 2013 and **LifeCycle®** guardrail dated June 2011.

2. Stair Guards

- (a) The guardrail systems can also be used as stair guards.
- (b) When the guardrail is used with stairs, the guardrail must be installed in accordance with the manufacturer's published installation instructions, noted in (c) below and in accordance with information located in Tables 1 and 2 in this report. When the manufacturer's published installation instructions differ from this report, this report governs. In order to comply with the IBC or IRC graspability requirements, the graspable handrail must be provided. Specific details regarding the construction installation and attachment of the graspable handrail to the stair guardrail and/or posts have not been evaluated and are outside the scope of this Research Report. Specific details when required must be furnished to the authority having jurisdiction.
- (c) For additional guardrail installation instructions, see manufacturer's published guardrail systems installation instructions as follows: **MoistureShield®** (Composite) guardrail dated July 2015, **ChoiceDek™** guardrail dated May 2013 and **LifeCycle®** guardrail dated June 2011

APPLICABLE CODES:

- 2015 *International Building Code®* (IBC)
- 2012 *International Building Code®* (IBC)
- 2009 *International Building Code®* (IBC)
- 2006 *International Building Code®* (IBC)
- 2015 *International Residential Code®* (IRC)
- 2012 *International Residential Code®* (IRC)
- 2009 *International Residential Code®* (IRC)
- 2006 *International Residential Code®* (IRC)

APPLICABLE CHARACTERISTICS REVIEWED:

B. Guardrail(s) - (*ChocieDeck™*, *MoistureShield®* and *Lifecycle®* Basics)

1. Guardrails: Structural Performance

- (a) The guardrail systems have been reviewed for maximum spans as indicated in Table 1. Table 1 in this report also indicates the limitations of use evaluated for each design.

2. Guardrails Durability: Temperature

- (a) The guardrail systems material described in this report has been reviewed for the temperature range of -20 degrees F (-29 degrees C) to +125 degrees F (52 degrees C).

3. Guardrails Flame Spread Index:

- (a) The flame spread rating for the guardrail system material, described in this report is less than 200 when tested with ASTM E84 "Standard Test Method for Surface Burning Characteristics of Building Materials."

4. Guardrails Decay Resistance:

- (a) The guardrail system material described in this report has been tested and is deemed comparable to naturally durable wood for resistance to fungal decay.

5. Guardrails Termite Resistance:

- (a) The guardrail system material described in this report has been tested and is deemed comparable to preservative treated wood for resistance to termite attack.

6. UV Testing:

- (a) The UV testing was conducted on the guardrail material described in this report and an appropriate adjustment factor was applied in accordance with ASTM D 7032-10 "Standard for Establishing Performance Ratings for Wood-Plastic Composite Deck Boards and Guardrail Systems (Guards or Handrails)".

APPLICABLE USES:

The AERT, Inc., guardrails evaluated in this report are limited to exterior applications with balconies, porches, stair treads, walking surfaces and decks.

LIMITATIONS OF ACCEPTANCE:

The AERT, Inc., guardrails described in this report comply with those codes listed in Applicable Codes section above and are subject to the following conditions:

1. The guardrail products are limited to exterior construction complying with the applicable requirements of the IRC and the IBC. The guardrail provides a protective barrier for walking areas, balconies, porches, stairs and ramps.
2. Installation of the guardrails must comply with this report, the manufacturer's published installation instructions (see A(1)(g) and A(2)(c) above) and the applicable code. When guardrail manufacturer's installation instructions differ from this report, this report governs.
3. The fasteners described in this report have been evaluated for the installation of the AERT, Inc., guardrails only, as described in this report. Framing support members for posts must be designed to satisfy load requirements (live and dead loads) indicated in the building code. Material necessary for anchorage of the guardrail system to supporting structures has not been evaluated. Compatibility of the fasteners to the treated supporting construction has not been evaluated.
4. The AERT, Inc., guardrails fastening to the supporting construction has not been evaluated.
5. The top rail component for the AERT, Inc., guardrail systems do not meet the grasp ability requirement when used as a handrail for stairs. See Description of Building Components A(2)(b) in this report for additional requirements.
6. When required, the guardrail systems in this report with stairs, (see Description of Building Components A(2)(b)), must be designed by a professional and submitted to the authority having jurisdiction for final acceptance.
7. The AERT, Inc., guardrails have not been evaluated as a member of a fire-resistance-rated assembly.
8. AERT, Inc., has Third Party inspections program provided by PFS Corporation (AA-652).

DOCUMENTATION SUBMITTED:

Submitted data was provided in accordance with PFS TECO 1601 (Quality control manual, Specifications, Manufacturer's installation instructions, Test data and Descriptive information) and tests were done and results evaluated in accordance with "Acceptance Criteria for Deck Board Span Ratings and Guardrail Systems (AC174)."

PRODUCT IDENTIFICATION:

The AERT, Inc., guardrails evaluated in this Research Report must be identified with a label, stamp, or laser imprint on the guardrail system. The information that is required is as follows: AERT, Inc., product identification, compliance to ASTM D7032 including the maximum guardrail span, the Research Report number (RR 0111), and PFS Certification Mark. Guardrails without this information are not covered under this report. Guardrails that are 36 inches high require a label indicating the following: "Guardrail installation in residential (1 & 2 Family) units only".

Table 1: Span Table for ChoiceDek®, MoistureShield®, and Lifecycle® Basics Guardrail Assembly

Guardrail Type	Top Rail Cap	Top Rail	Bottom Rail	Baluster	Post	Max Guardrail Span
Maximum Guardrail Height 36 in. for IRC Residential One- and Two-Family Residential Dwellings						
Design 1	3-1/2" Optional	3-7/8"x2-7/8"	3-7/8"x2-7/8"	2x2" WTCL 4" inside openings	4x4" Standard Unreinforced	5'-4"
Design 2	2x6"	2x4"	2x4"		4x4" Standard Unreinforced	6'-0"
Design 3	2x4"	2x4"	2x4"		4x4 Wood Post with 4x4 WTCL Post Sleeve	6'-0"
Maximum Guardrail Height 42 in. for IBC All Occupancies						
Design 1	3-1/2" Optional	3-7/8"x2-7/8"	3-7/8"x2-7/8"	2x2" WTCL 4" inside openings	4x4" Standard Unreinforced	5'-4"
Design 2	2x6"	2x4"	2x4"		4x4" Standard Reinforced	6'-0"
Design 3	2x4"	2x4"	2x4"		4x4 Wood Post with 4x4 WTCL Post Sleeve	6'-0"

for SI conversion: 1 in = 25.4 mm, 1 psi = 47.9 Pa, 1 lbf = 0.0044 kN

Refer to Table 2 for fastening schedule

Maximum span is the center to center spacing of posts

Table 2: Schematics for ChoiceDek®, MoistureShield®, and Lifecycle® Basics Guardrail Assembly Systems

Guardrail Assembly Type	Schematics of The Guardrail System
Guardrail Design 1	 <p>Top View Dimensions: Total width: 72" Max Inside opening between balusters: 4" Max Post width: 4" Min Baluster spacing: 24" Max Post offset from deck surface: 1 1/2" Min Baluster offset from deck surface: 4" Max Post offset from deck structure: 3" Max Baluster offset from deck structure: 4" Min</p> <p>Side View Dimensions: Total height: 42" Max Top Guardrail Cap thickness: 3 1/2" Baluster height: 1 1/4" Top Guardrail height: 3 7/8" Baluster to Post offset: 2 7/8" Rail to Baluster offset: 1 1/4"</p> <p>Callouts: Top Guardrail Cap Top Guardrail Post Balusters Support Blocks 1 1/2" min & 4" max, 24" max inboard from Post Bottom Guardrail (2x4 Deck Board) Deck Surface Post attached to Deck Structure using blocking between joists 1 Screw per Baluster location 1 Deck Screw minimum at Top & Bottom Guardrails With Guardrail Cap Without Guardrail Cap</p> <p>Fastening Details: Top Guardrail to Post: 4-#7x2-1/4" Deck Screws (2 Diagonal & 2 Vertical) Baluster to Post: 4-#7x2-1/4" Deck Screws Rail to Baluster: 2-#7x2-1/4" Deck Screws at Top & Bottom</p>
Guardrail Design 2	 <p>Top View Dimensions: Total width: 72" Max Inside opening between balusters: 4" Max Post width: 4" Min Baluster spacing: 24" Max Post offset from deck surface: 1 1/2" Min Baluster offset from deck surface: 4" Max Post offset from deck structure: 3" Max Baluster offset from deck structure: 4" Min</p> <p>Side View Dimensions: Total height: 42" Max Top Guardrail height: 3 7/8" Baluster height: 1 1/4" Top Rail height: 3 7/8" Baluster to Post offset: 2 7/8" Rail to Baluster offset: 1 1/4"</p> <p>Callouts: Top Guardrail (2x6 Deck Board) Top Guardrail (2x4 Deck Board) Post Balusters Support Blocks 1 1/2" min & 4" max, 24" max inboard from Post Bottom Guardrail (2x4 Deck Board) Deck Surface Post attached to Deck Structure using blocking between joists (2) Deck Screws at Top & Bottom Rails Top Rail Baluster Bottom Rail</p> <p>Fastening Details: Top Guardrail to Post: 4-#7x2-1/4" Deck Screws (2 Diagonal & 2 Vertical) Baluster to Post: 4-#7x2-1/4" Deck Screws Rail to Baluster: 2-#7x2-1/4" Deck Screws at Top & Bottom</p>

Table 2 Continued

<p>Guardrail Design 3</p>	<p>(2) #8x3" SS Trim Screws (min.)</p> <p>(2 each, Top and Bottom) #7x2-1/4" SS Trim Screw (min.) Connecting Baluster Adjacent to Post to the Rail</p> <p>(1 Each, Top and Bottom) #8x3" SS Trim Screw (min.)</p> <p>Composite 4x4 Post Sleeve (Or Composite 4x4 Post)</p> <p>6"</p> <p>1-1/2"</p> <p>Composite Baluster (Nominal 1.27"x1.5")</p> <p>SECTION C-C</p> <p>4x4 Wood Post (Wood Post Excluded if Using 4x4 Composite Post)</p> <p>(5) #8x3" SS Trim Screws (min.), 1 Each End, 3 Evenly Distributed</p> <p>Cap to Rail Connection</p> <p>Baluster to Rail Connection</p> <p>Composite 2x4 (Nominal 1-1/2"x3-1/2")</p> <p>(1 Each, Top and Bottom) #7x2-1/4" SS Trim Screw (min.)</p> <p>42" Max</p> <p>4" Max</p> <p>4" Max Opening</p> <p>Support Blocks or Extended Balusters 24" Max From Inside Post</p> <p>72" OC Max</p>
<p>Guardrail Components</p>	<p>4.38 ± 0.03 in.</p> <p>3.78 ± 0.03 in.</p> <p>Radius 0.13 in (typical)</p> <p>Radius 0.25 in</p> <p>0.30 in (typical)</p> <p>90° ± 0.05°</p> <p>4.27</p> <p>4.27</p> <p>Hollow Core</p> <p>5.40</p> <p>1.40</p> <p>2.92</p> <p>1.60</p> <p>1.50</p> <p>1.27</p> <p>1.50</p> <p>4x4 WTCL Post Sleeve</p> <p>4x4 Post</p> <p>2x6 Guardrail Cap</p> <p>Top Guardrail</p> <p>2x2 WTCL Baluster</p> <p>3.50</p> <p>1.50</p> <p>2x4 Deck Board (Top or Bottom Rail)</p> <p>1.66</p> <p>0.14</p> <p>Reinforcing Pipe (Min Length 18")</p>

Table 2 Continued

<p>Guardrail Post to Frame Connection Option 1</p>	 <p>Reinforced</p> <p>Non-Reinforced</p> <p>Framing By Others</p> <p>Framing By Others</p> <p>Reinforced Insert $1\frac{1}{4}$" Pipe (1.660") x 0.140" Min. Wall Thickness x 18" Min. Length Pipe Must Be Flush With Bolt Of Post and Extend At Least $10\frac{3}{4}$" Above Top of Joist.</p> <p>Block Post & Attach to Post Blocking With (2) $\frac{3}{8}$" Diameter Bolts At Center of Post, Parallel to Rail.</p>
<p>Guardrail Post to Frame Connection Option 2</p>	 <p>Reinforced</p> <p>Non-Reinforced</p> <p>Reinforced Insert $1\frac{1}{4}$" Pipe (1.660") x 0.140" Min. Wall Thickness x 18" Min. Length Pipe Must Be Flush With Bolt Of Post and Extend At Least $10\frac{3}{4}$" Above Top of Joist.</p> <p>Block Post & Attach to Post Blocking With a Bolt At Center of Post, Perpendicular to Rail</p> <p>Exterior Grade Screws (1) Toe-nail on Each Side of Post. (2) Horizontal Through Rim Joist.</p>

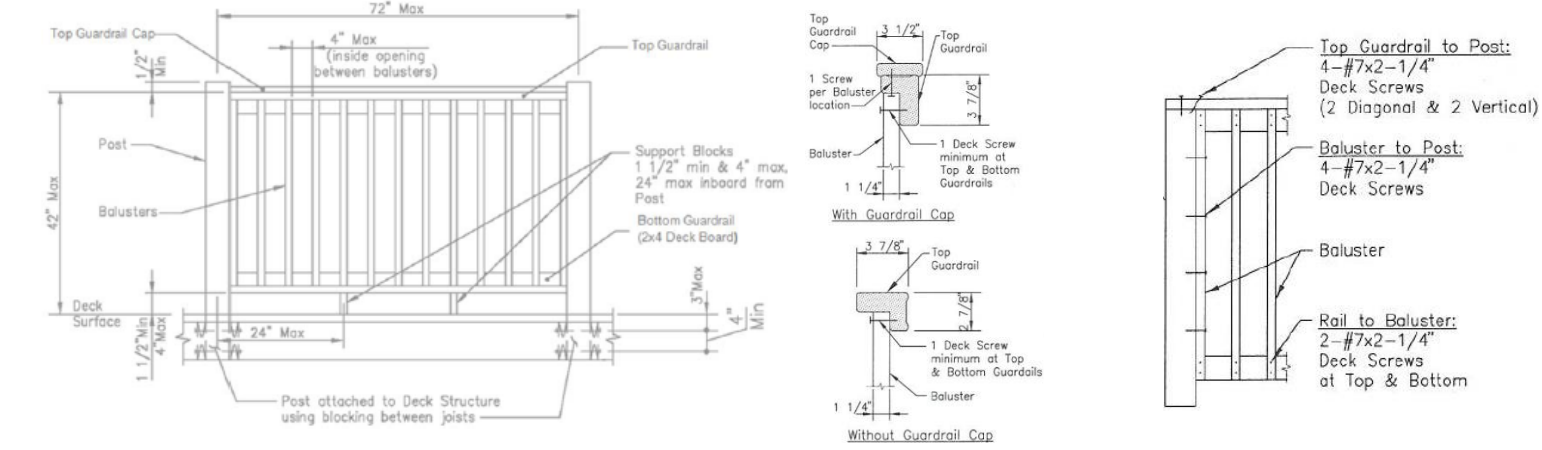
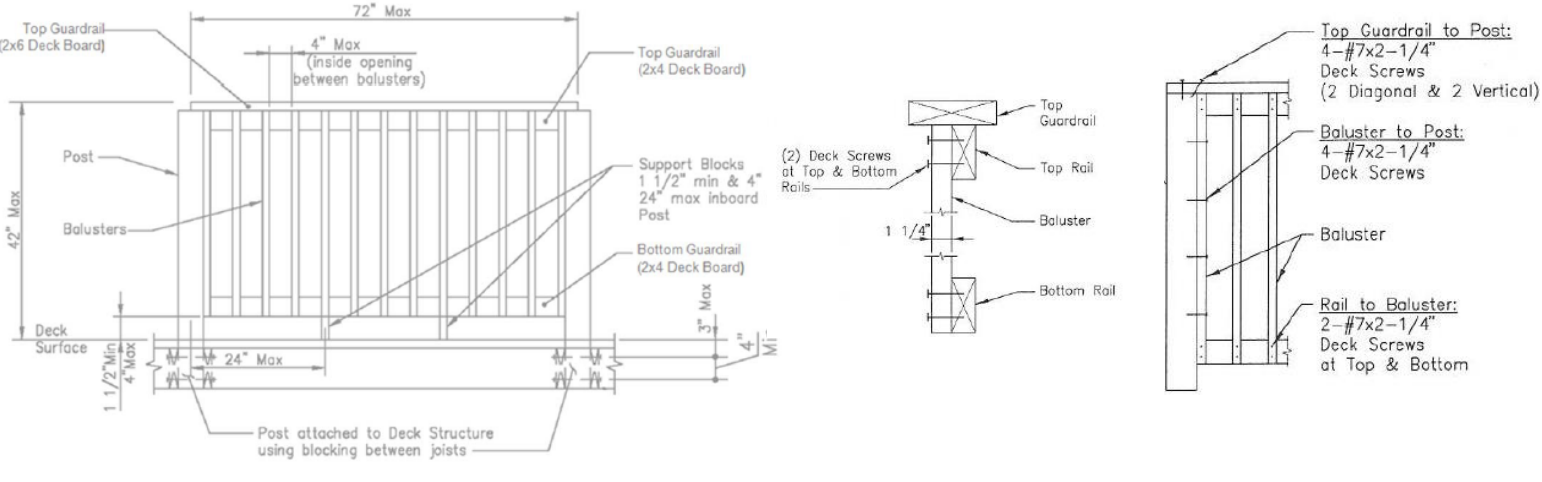
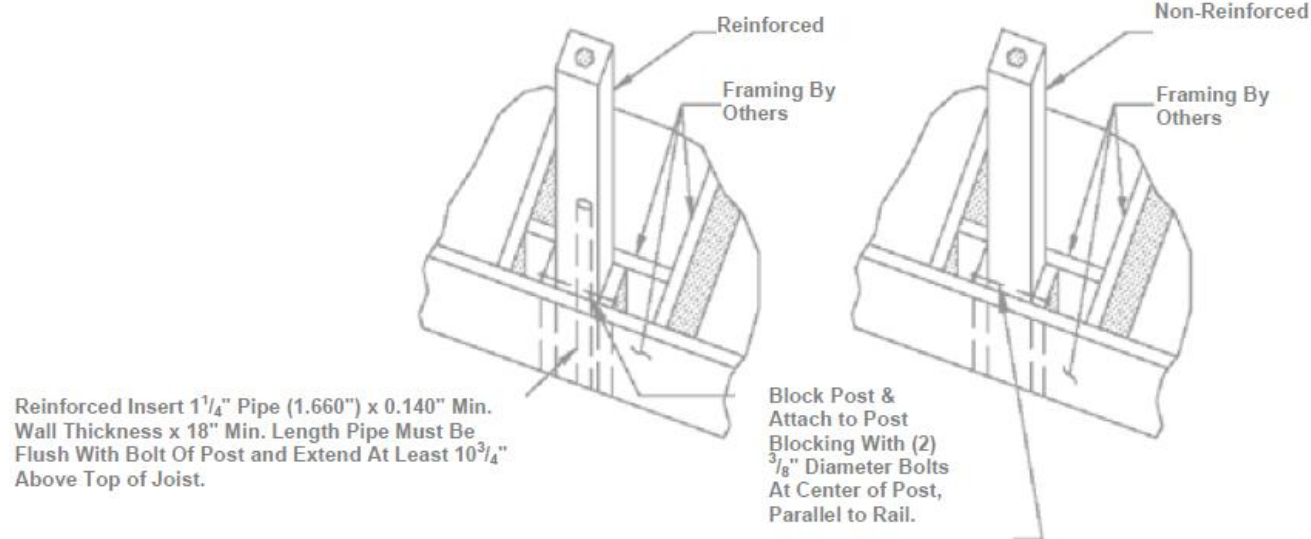
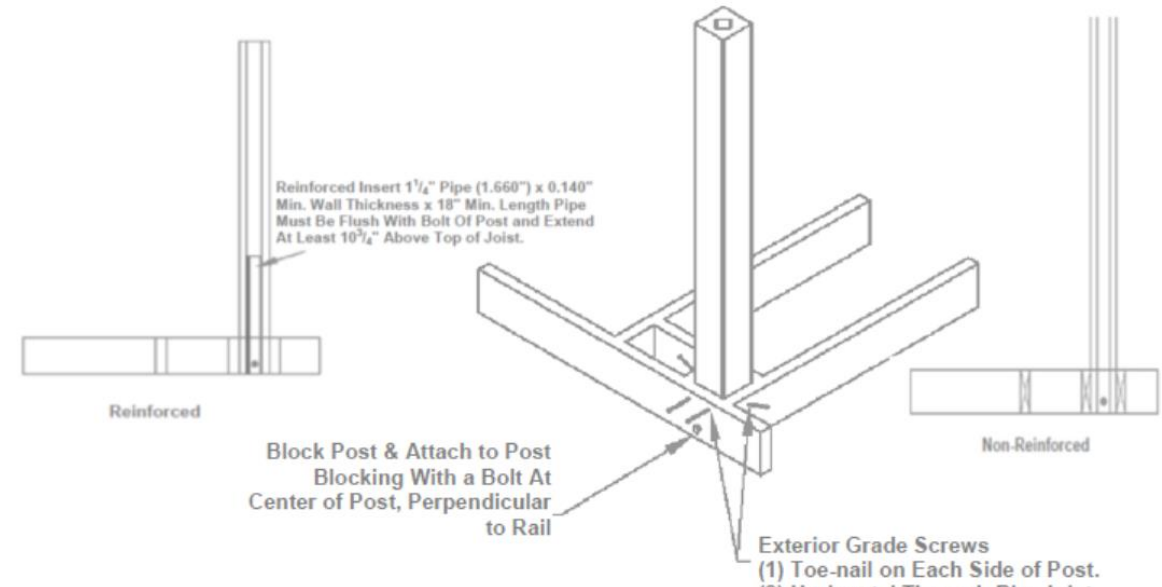
Notes:

1. The schematics notes in Table 2 are for illustration purpose only, not intended for design.
2. Wood posts are not evaluated in this report. When required, the wood posts must be designed by a professional and the design must be submitted to the authority having jurisdiction for the final acceptance. Minimum specific gravity of the posts must be 0.48.